

Models AH, C, B-DBL, CB and Pizza Quick Setup Instructions

WARNING: Electrical and plumbing connections need to be made by a licensed service person and comply with all Federal, State and Local Health, Electrical, Plumbing and Safety codes.

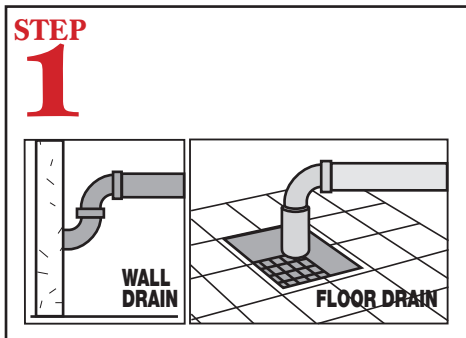

Connect the drain pipe from scrap accumulator to floor or wall drain.

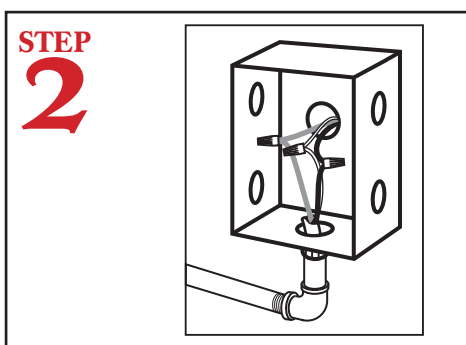

Connect hard wire power supply from dishmachine to power box.

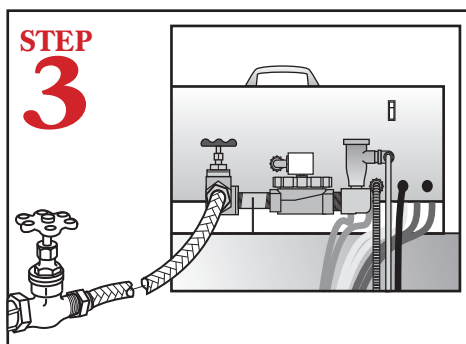

Connect dishmachine to hot water source recommended 140 temperature (120 minimum temperature required).

MODEL AH REAR VIEW

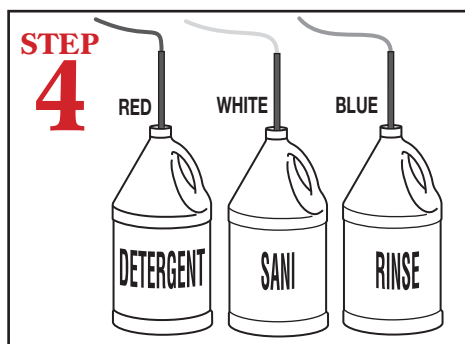
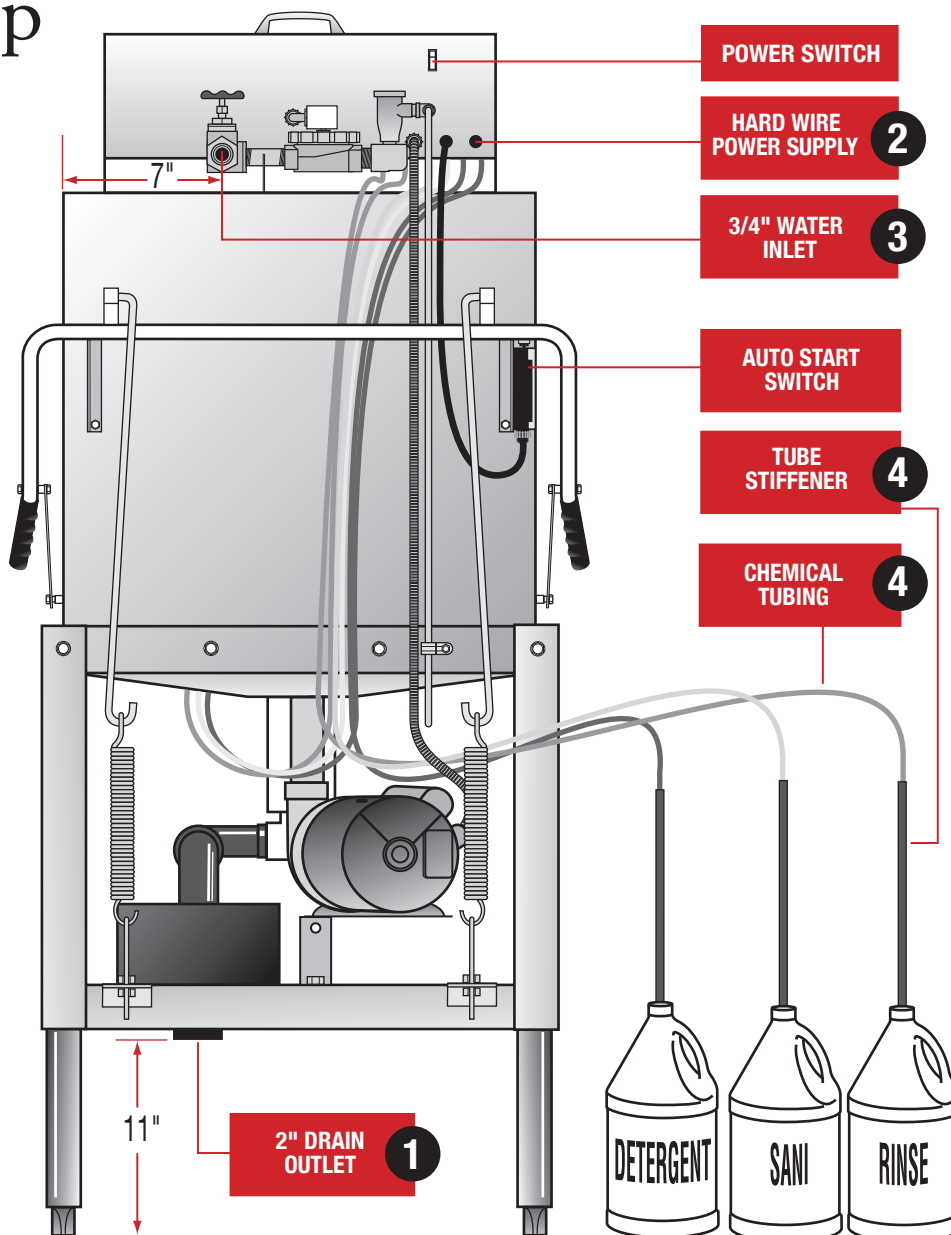

Insert tube stiffener with chemical tubing into each corresponding chemical dispensers.

Models AH, C, B-DBL, CB and Pizza Quick Setup Instructions

MODEL AH FRONT VIEW

WARNING: Electrical and plumbing connections need to be made by a licensed service person and comply with all Federal, State and Local Health, Electrical, Plumbing and Safety codes.

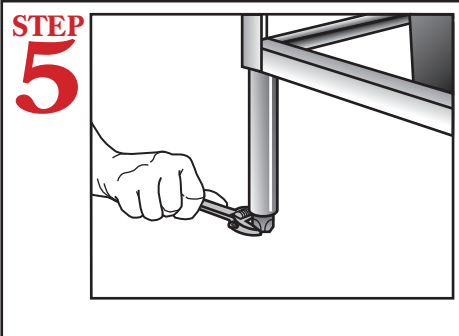

Level dishmachine by adjusting leveling legs. Dishmachine must be level front and back to ensure proper performance.

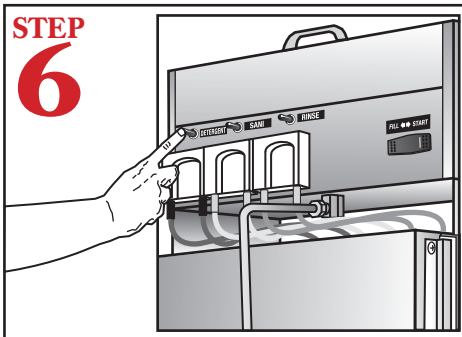

Press and hold down the three Primer Toggle Switches for the chemical pumps until product is discharging into the machine.

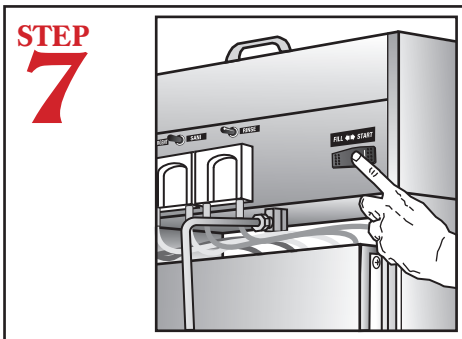

Press and hold the Fill/Start Switch until the water level is approximately 1/2" to 3/4" below the overflow hole in the PVC standpipe.

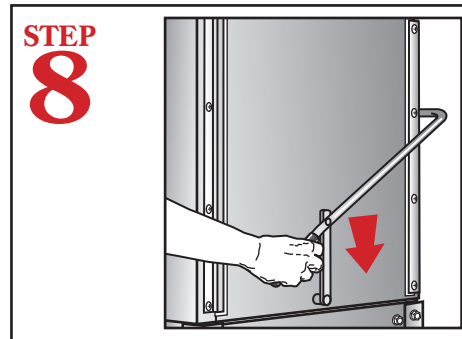
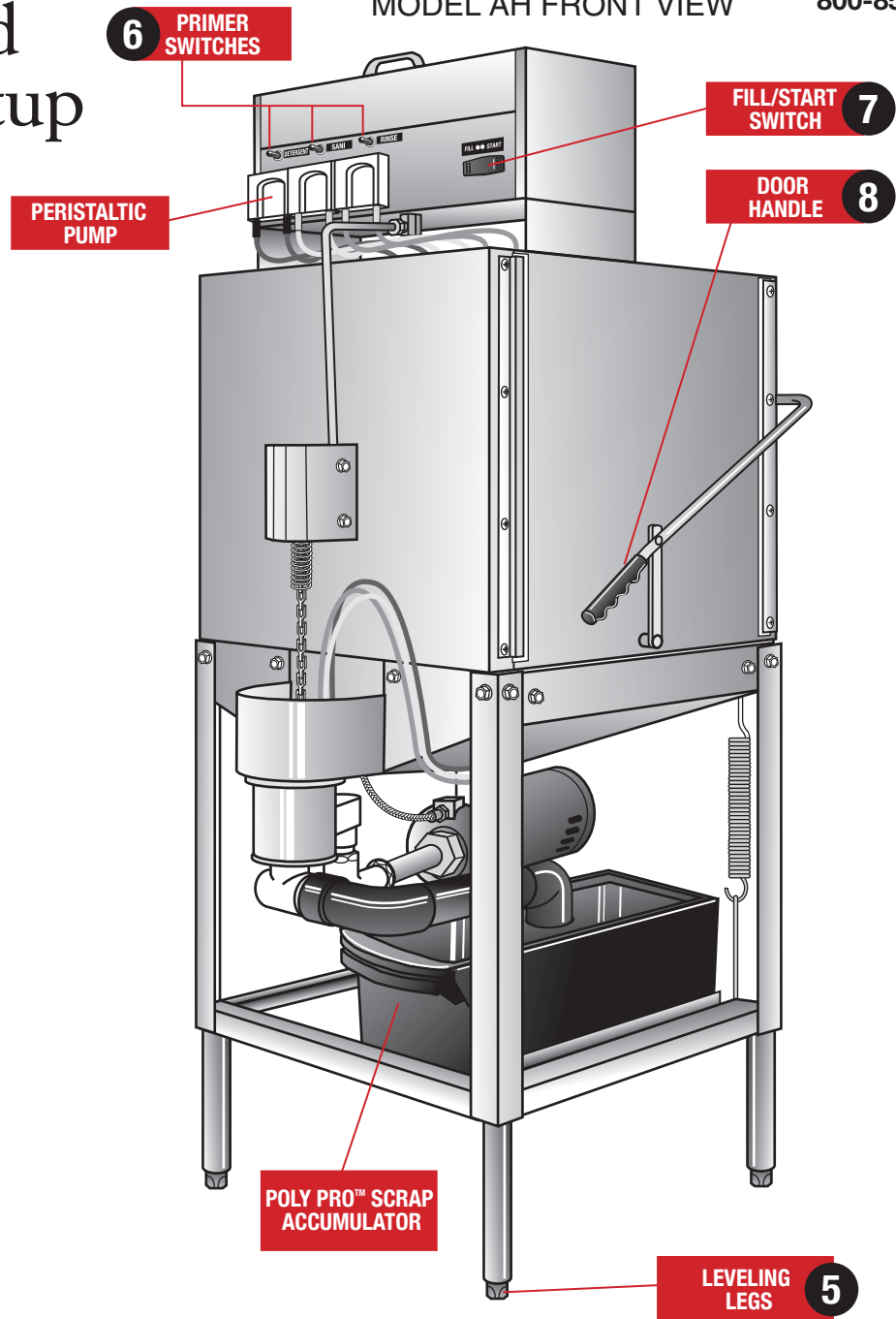

To start machine close the doors. The machine will automatically start and run through its cycle.